



# FITTING INSTRUCTIONS

## 6178014 FORD RANGER MY22+ & VW AMOROK MY23+ REAR TUB SEALING KIT

To Suit Thailand built Ford XL, XLS, XLT, Sport and Raptor Models in Dual CAB & Extra CAB Chassis  
(Kit is not required on Models with Ford OEM Lockable Roll Top, standard on Wildtrak and Platinum)

To Suit South African built VW Core, Life, Style, Pan America and Aventura Models in Dual CAB & Extra CAB Chassis

(Kit is not required on Models with VW OEM Lockable Roll Top, standard on Aventura)

**Canopy fitment is to be undertaken first prior to the fitment of this kit.**

**This kit is designed to reduce water ingress to the tub and is only to be used when canopies are fitted.**

**Estimated fitting time 1 hour.**

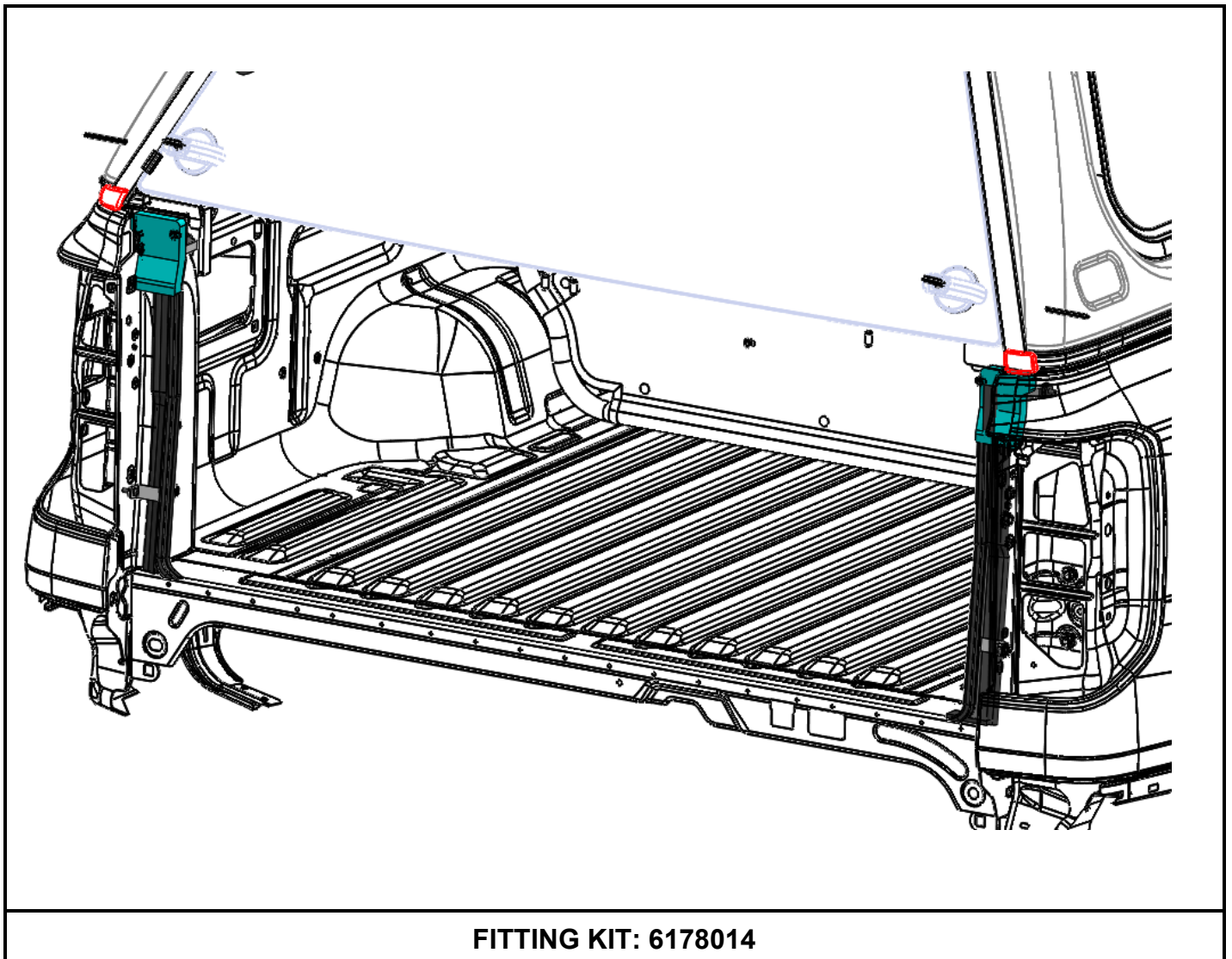



**FITTING KIT: 6178014**

## IMPORTANT

- ◆ This product must be installed exactly as per these instructions using only the hardware supplied.
- ◆ **Failure to follow instructions precisely may lead to failure of the product.**
- ◆ The installation of this product may require the use of specialized tools and/or techniques.
- ◆ During installation, it is the duty of the installer to check correct operation/clearances of all components.
- ◆ Work safely at all times.
- ◆ Specific installation can vary, so please read the following instructions as they refer to important information, which could affect the quality of the final installation.
- ◆ It is advisable to have these parts fitted by an authorised dealer.
- ◆ **Ensuring that the specified torques are used as contained in this fitting instruction, is imperative, as failure may occur.**
- ◆ IF IN DOUBT CONTACT ARB FOR FURTHER INSTRUCTION.

### HAVE AVAILABLE THESE SAFETY ITEMS WHEN FITTING PRODUCT:

Protective eyewear		Hearing protection		Gloves	
--------------------	---	--------------------	--	--------	---

*NOTE: 'WARNING' notes in the fitting procedure relate to OHS situations, where to avoid a potentially hazardous situation it is suggested that protective safety gear be worn or a safe work procedure be employed. If these notes and warnings are not heeded, injury may result.*

### TOOL LIST FOR FITMENT:



<ul style="list-style-type: none"><li>• Sharp shears</li><li>• T30 Torx key</li><li>• Torque Wrench</li></ul>	<ul style="list-style-type: none"><li>• Pliers</li><li>• Rags</li><li>• Non- acetic Silicon Sealant</li></ul>
---	---



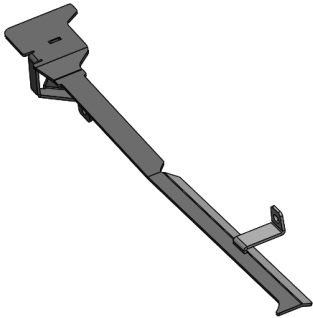
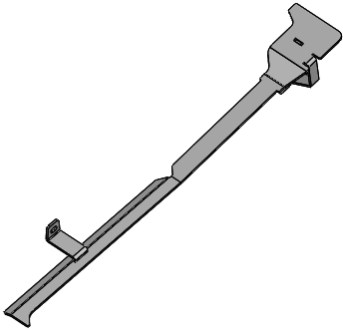
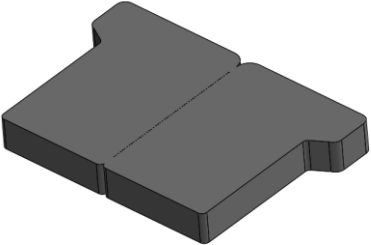

## **!! IMPORTANT !!**

**REQUIRED SCREW TORQUES: Refer to steps in fitting instruction**

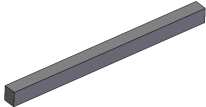
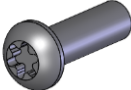
**Screw torques must be adhered to. Over torqueing can cause failure of components.**

**THE FITTING KIT CONTAINS:**

KIT	Part No	Picture	Qty	Description
<b>Box Kit 6178014</b>	668AQ032R		1	TAILGATE SEALING BRACKET ASSEMBLY – RIGHT HAND
	668AQ032L		1	TAILGATE SEALING BRACKET ASSEMBLY – LEFT HAND
	668PB036		1	PAIR OF DIE CUT FOAM SEALS
	9009473		2	PINCHWELD SEAL – 500mm LENGTH (LARGER SEAL BULB SIZE)
	9009472		2	PINCHWELD SEAL – 500mm LENGTH (SMALLER BULB SEAL SIZE WITH DOUBLE FINS)
	668PB011		1	SEALING FOAM TAPE 15X18, 300MM LONG
	6151622		4	T30 TORX PAN HEAD M6 x 20MM SCREW - BLACK

	4584424		4	M6 x 18 x 3mm WASHER – BLACK
	4584421		4	M6 x 18 x 1.6mm NYLON PLASTIC WASHER
	4584329		4	M6 x 12 x 1.2 WASHER – BLACK
	6602018		1	ALCOHOL WIPE

## **SECTION 1: PREPARATION OF BRACKETS AND INSTALLATION**

### **Section 1: Rear Sealing Bracket Preparation and Installation**

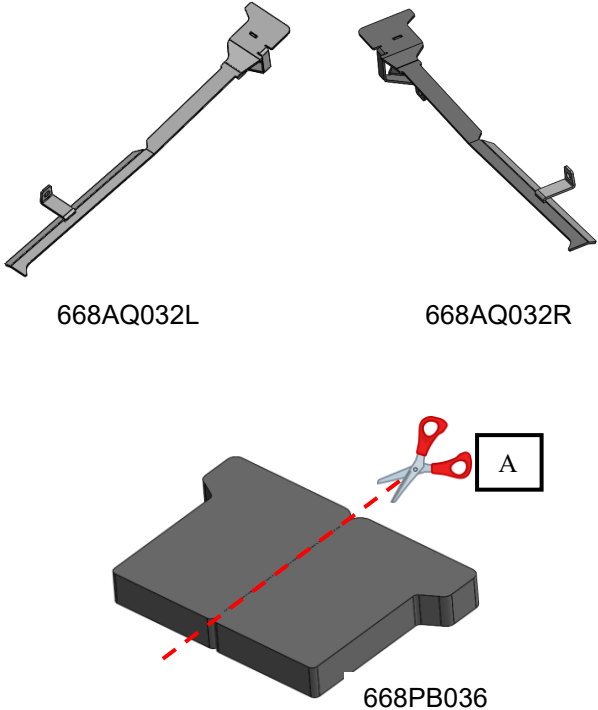
 <p>668AQ032L                      668AQ032R</p> <p>668PB036</p>	<ol style="list-style-type: none"> <li>1.0) Unpack the tailgate sealing assembly brackets (668AQ032R&amp;L) and die cut seal pair (668PB036).</li> <li>1.1) Separate the die cut seals (668PB036) into two handed parts as shown (A).</li> </ol>
--	--

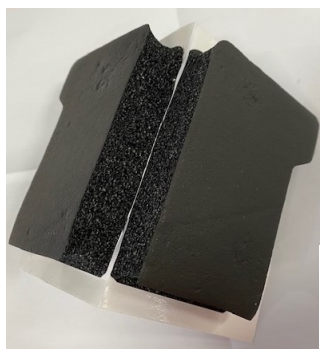

SEPARATE LH AND RH  
FOAM PADS

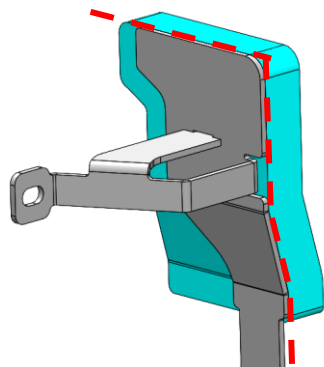

ALIGN EDGES OF FOAM  
PAD TO BRACKET

- 1.2) Remove the backing paper on one side.
- 1.3) Adhere right and left foam pad to rear corner tailgate sealing bracket (668AQ032R/L) respectively, right hand bracket shown.
- 1.4) Align top edge and inner edge of bracket with foam pad as shown. Repeat for LH side bracket.

RHS  
SHOWN

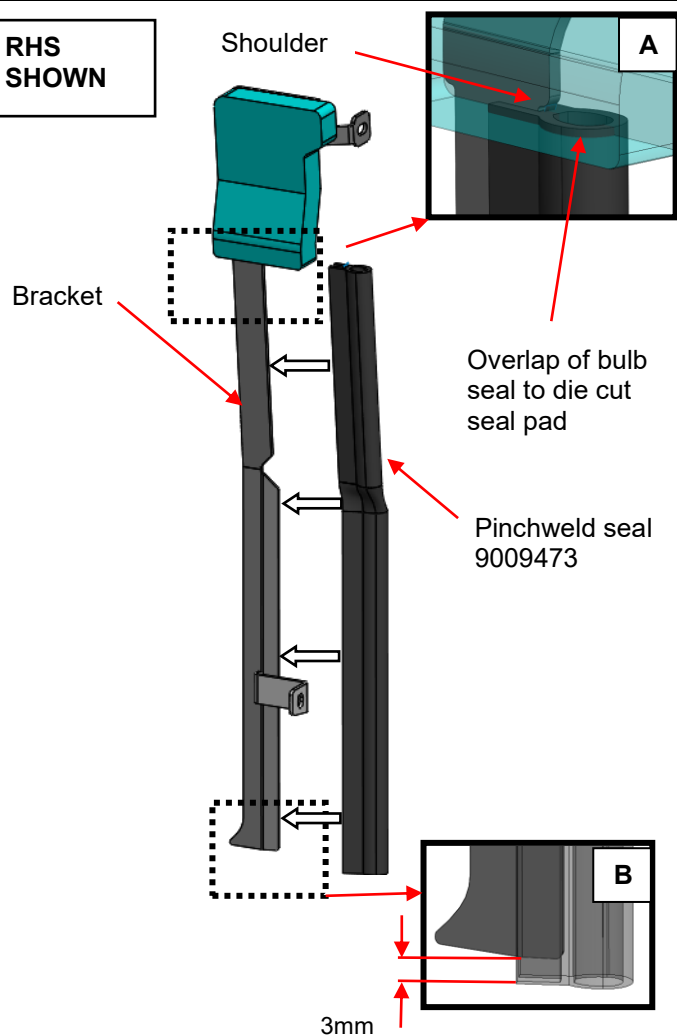

- 1.5) Install the two 500mm long larger sized pinch weld bulb seals (9009473) onto the brackets (668AQ032R&L).
- 1.6) On installation of the pinchweld seals, ensure that they push hard up against the top shoulder of rear sealing bracket and that there is some overlap of foam seal onto the end of the pinchweld seal ensuring a good seal at (A).
- 1.7) At the lower end of the bracket cut excess pinchweld with sharp shears (neatly, in one straight cut) allowing 3mm extra in length from the end of the bracket as shown (B) and ensure pinch-weld is pushed fully onto the edge of the bracket. Remove any steel protruding out of the end of the pinchweld seal with pliers.
- 1.8) Repeat the above steps for left-hand rear sealing bracket.

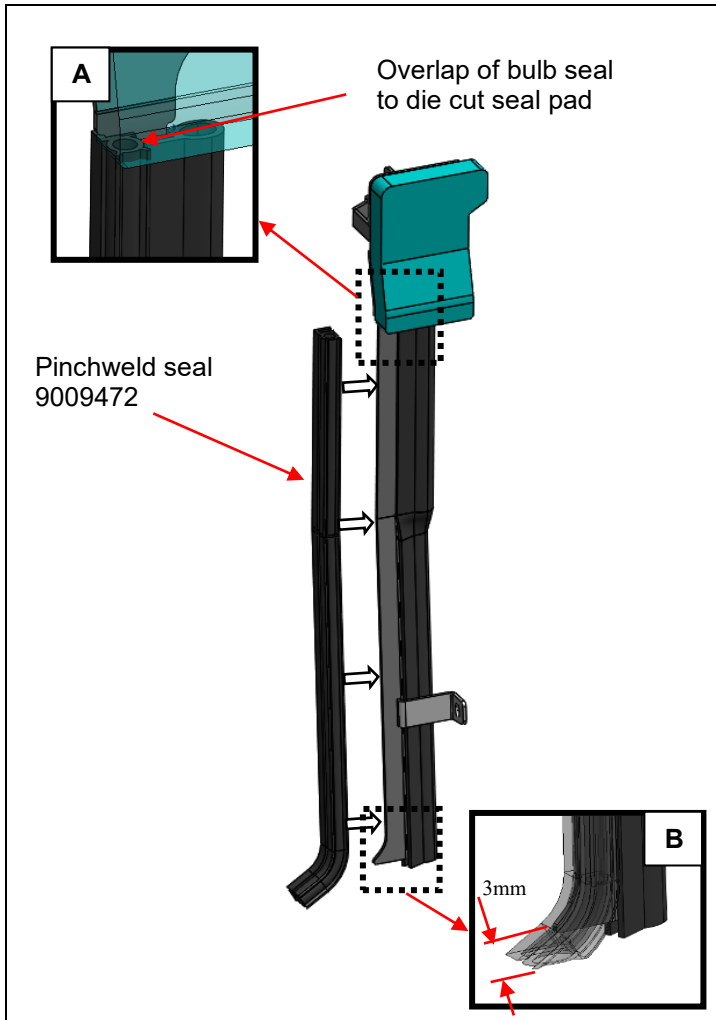

1.9) Install the two 500mm long smaller sized pinch weld bulb seals (9009472) onto the rear sealing brackets on the inner edges (668AQ032R&L).



1.10) On installation of the pinchweld seals, ensure that they push hard up against the top shoulder of rear sealing bracket and that there is some overlap of foam seal onto the end of the pinchweld seal ensuring a good seal at (A).

1.11) At the lower end of the bracket cut excess pinchweld with sharp shears (neatly, in one straight cut **so the ends are parallel to the tub floor**) allowing 3mm extra in length from the end of the bracket as shown (B) and ensure pinch-weld is pushed fully onto the edge of the bracket. Remove any steel protruding out of the end of the pinchweld seal with pliers.

1.12) Repeat the above steps for left-hand rear sealing bracket.

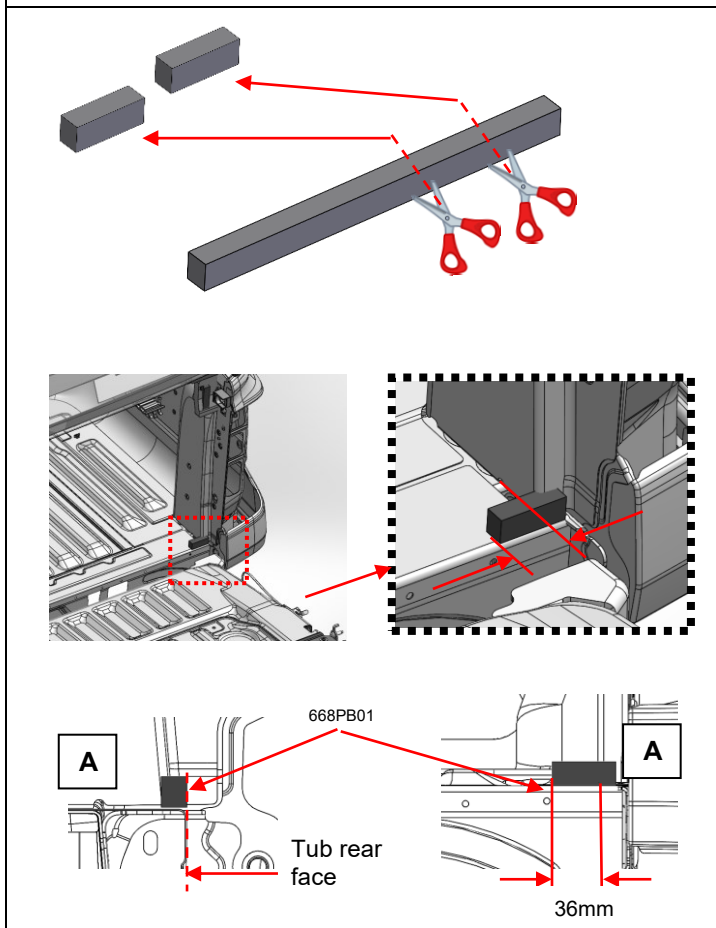

1.13) Unpack seal 668PB011 (300mm Long) and cut the seal into two (2) equal 50mm equal length sized seals.

1.14) Peel off the backing from the foam double sided tape and **position the seal flush to the end of the tub recess in the pillar and 36mm away from the innermost wall of the side tub pillar as shown (A).**

**NOTE: Ensure to clean area using Alcohol Wipe provided in this kit before applying 668PB011.**

1.15) Repeat for left-hand side

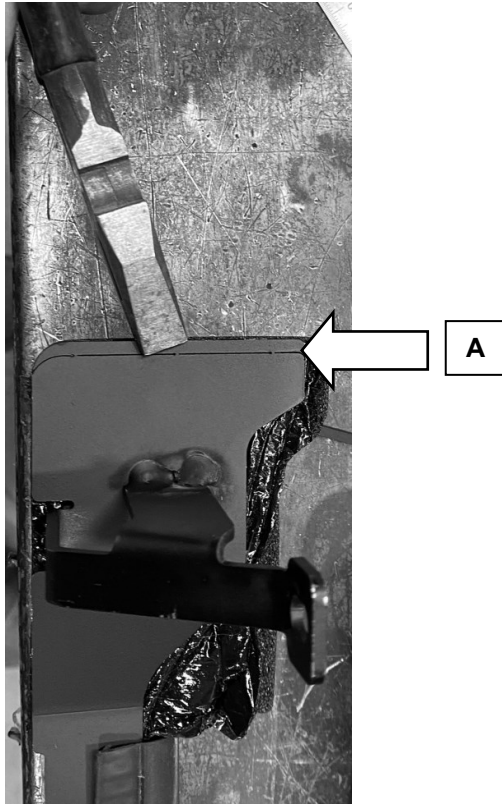

- 1.16) **IMPORTANT STEPS DEPENDANT ON WHICH TYPE OF CANOPY IS FITTED, BEING ASCENT OR CLASSIC / CLASSIC PLUS:**  
**BREAK-AWAY**  
 Look on the inner side of the brackets (Where the brackets are laser slitted at the top): **Only if an ARB Ascent Canopy is fitted** the Rear Tub Sealing Brackets requires “break-away” to be broken-off at the top before fitment of bracket to the rear tub. **Leave the die cut seal pad long past the bracket’s top**
- 1.17) **For installation with Ascent Canopy only**, break-away the piece on the bracket as shown (A) with a pair of pliers. Repeat for opposite side.

**Note: There is no action required if an ARB Classic of Classic Plus Canopy is fitted.** The break-away piece to remain in place.

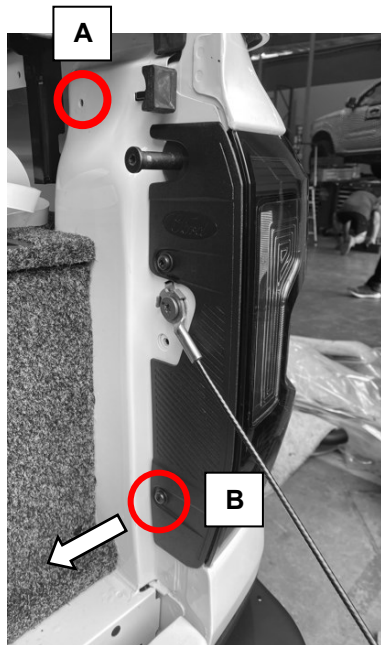

- 1.18) Locate the lower rear tail light M6 fastener, remove and discard both washer and screw at (B) for both right hand and left-hand side of the vehicle.
- 1.19) Upper fastening point shown at (A) is used for bracket installation.

Two M6 X 3mm thick-Washers are not required When a Ford Tub Liner is Fitted

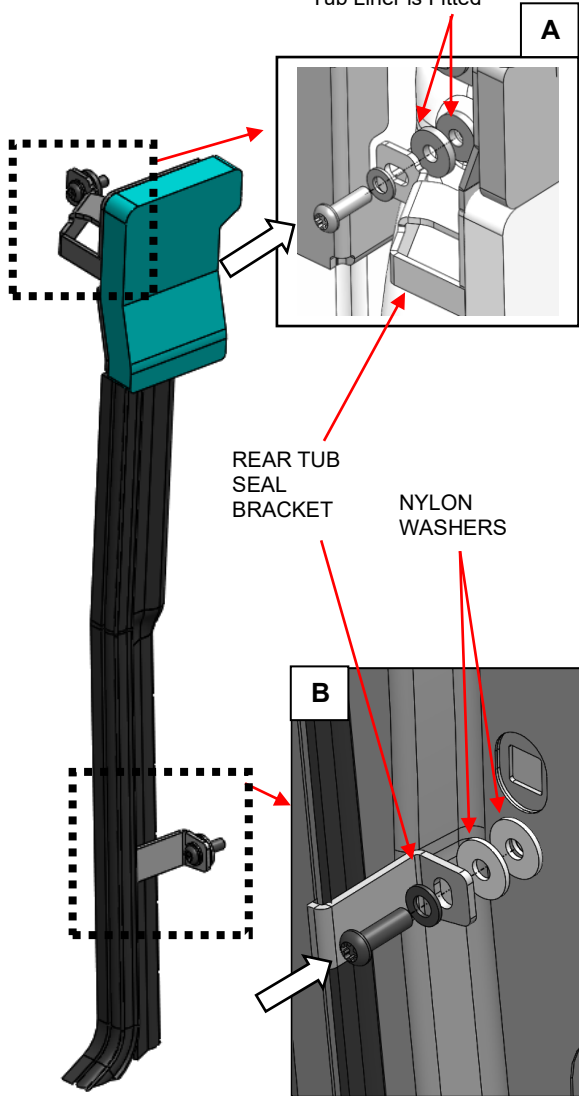

1.20) Loosely fasten the upper attachment point of the brackets to the vehicle's tub at (A) , using the T30 Torx M6 x 20mm screw (6152129) , M6 x 18 x 1.2 Washer (4584329) under the head of the screw through the bracket and two M6 x 18 x 3mm thick washers (4584424) on the opposite side of the bracket **(NB: These washers are not required if a Ford/VW OEM tub liner is fitted)** to attach to the vehicle with a T30 torx drive. (A).

**NOTE:**

If the Ford/VW OEM plastic Tub Liner is fitted, the Two (2) M6 x 3mm thick washers (4584424) are not required. See below, For Ford Raptor with spay-on tub liner the two (2) M6 x 3mm washer are required as shown (A).

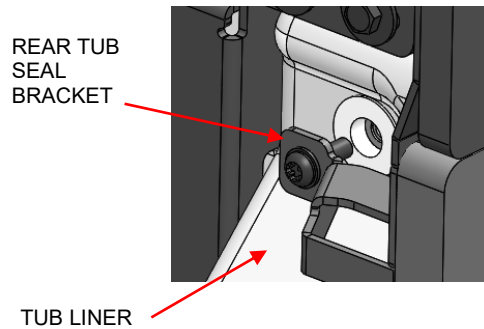

1.21) Then loosely fasten the lower attachment point, using T30 Torx M6 x 20mm screw (6152129), M6 x 18 x 1.2 Washer (4584329) under the head of the screw through the bracket and two M6 x 18 x 1.6mm thick nylon washers (4584421) on the opposite side of the bracket (B).

1.22) Ensure pinchweld seal is properly seated on the brackets and fasten all fasteners to **9Nm of Torque**.

1.23) Ensure lower tub seal 668PB011 is sitting neatly under the rear sealing bracket and pinch weld seals before moving on to next step, (C).

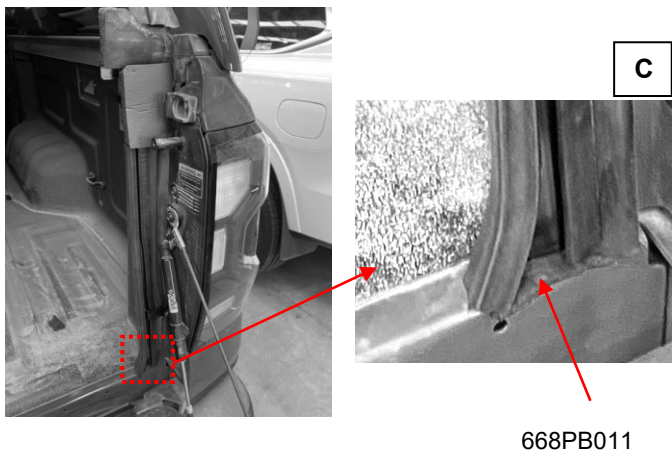

1.24) Repeat **Steps 1.13 to 1.23** for the left-hand side.



## Section 2: SILICON AND INSTALLATION OF ADDITIONAL TUBSTOP SEAL

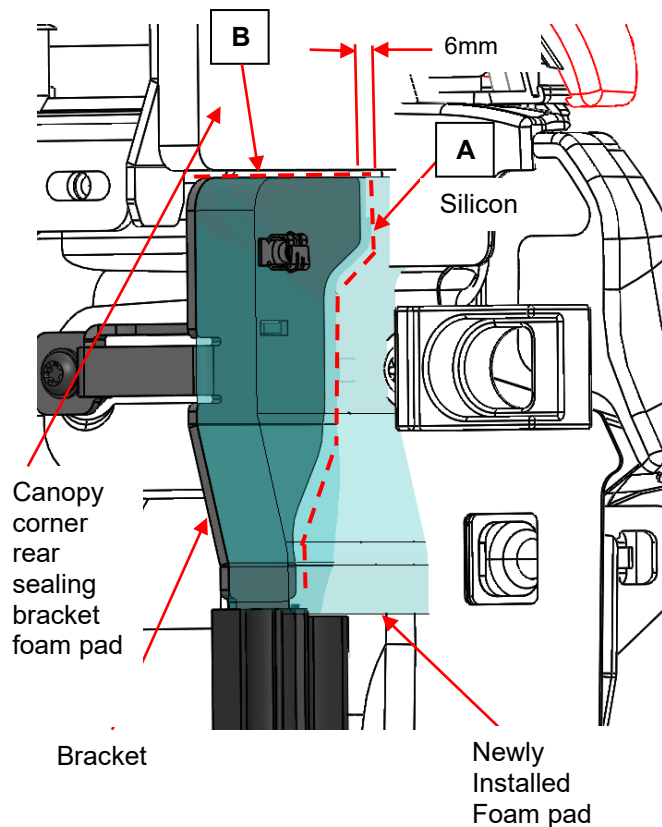

- 2.2) To ensure a good seal between Newly installed rear tub sealing bracket and its foam pad, run a bead of silicon between the foam pad and the side of the tub for the whole vertical length of the foam pad (along the line at A), and again on the inside of the bracket at the 6mm gap between the steel of the bracket and the tub sheet metal. **Apply another horizontal bead of silicon at the join between existing canopy corner sealing bracket foam pad and newly installed tub sealing bracket foam pad (B).** Wipe any excess silicon off and repeat for opposite side.

**NOTE:** Clean rear tub surfaces with alcohol wipe provided, before applying silicon.

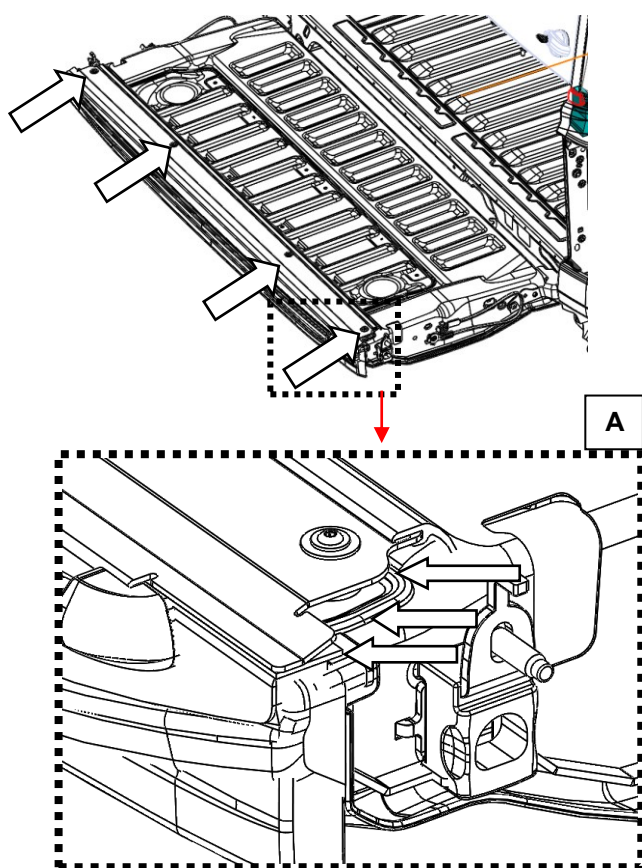

- 2.3) Unpack remaining tape seal 668PB011, cut 2 lengths 80mm

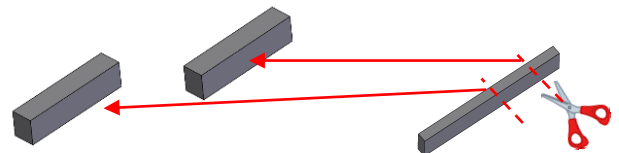

- 2.4) Loosen the four screws on the tailgate door tub stop assembly that is fitted when installing a canopy, (do not remove) enduring threads are still engaged to retain spacers and washers in place.

- 2.5) Take alcohol wipe supplied with kit and clean tailgate inner surface at (A) behind the canopy rear door tailgate sealing stop assembly.

- 2.6) Peel backing paper off the foam seal and place it between the tub stop assembly, with the adhesive side placed on the inside of the tailgate with the foam tape outer edge following the outer edge of the tub stop assembly when looking down on the open tailgate. (Tape should be applied behind the tailgate tub stop assembly adhesive side the tailgate). See next step.

Tub stop profile

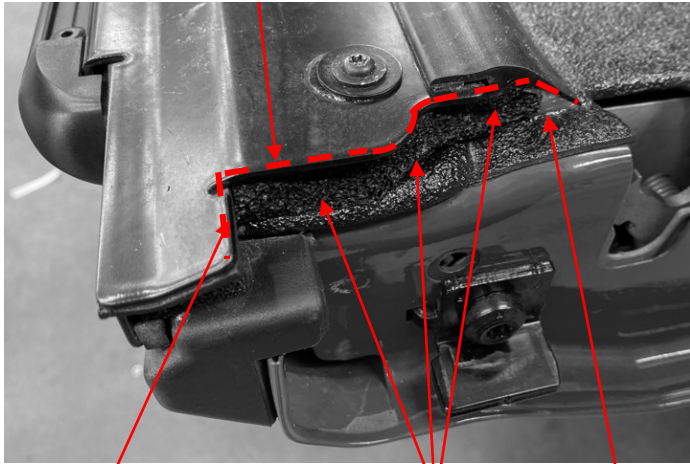

Starting edge of foam tape

Foam tape aligned to edge of bracket

End

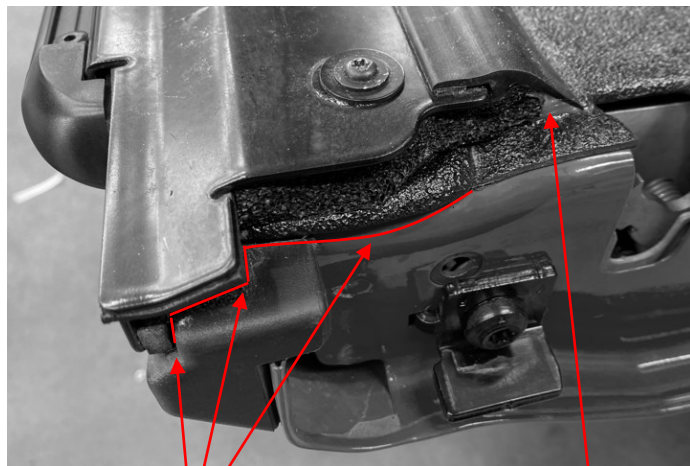

Silicon bead along this path

Fill void at flap seal edge

- 2.7) The foam tape should be placed between the tub stop assembly and tailgate inner, with the adhesive side placed down on the inside of the tailgate and the tape edge should follow the outer edge of the tub stop assembly so it is behind it (B).

**Note:** Ensure that the seal follows the profile of the side on the tub stop at starts firmly up against edge of tub stop and runs all the way to the end rubber lower strip seal. as shown (B).

- 2.8) Repeat for left-hand side on tailgate.

- 2.9) Retighten tub stop screws to **1.5Nm** in 4 places, **while tightening at each torx screw position apply pressure to tub stop in direction (A) as indicated to ensure tub stop in seated correctly. !! Be careful not to strip the screws !! If necessary, tighten by hand and use the torque wrench.**

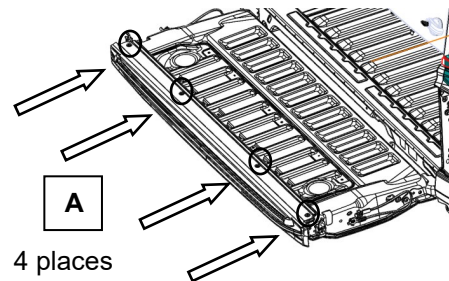

- 2.10) Apply a bead or silicon in the indicated areas (opposite), filling voids. Repeat for other side.

- 2.11) Clean any excess silicon off both sides and allow to dry.

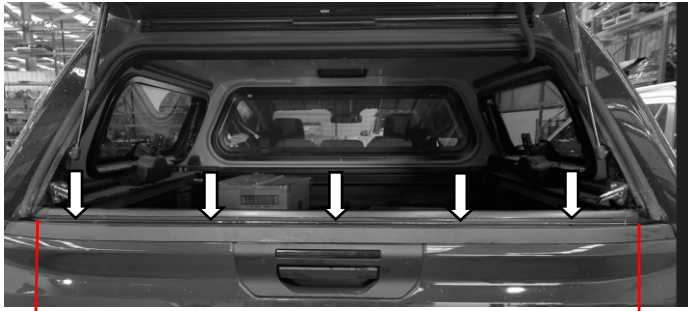

A

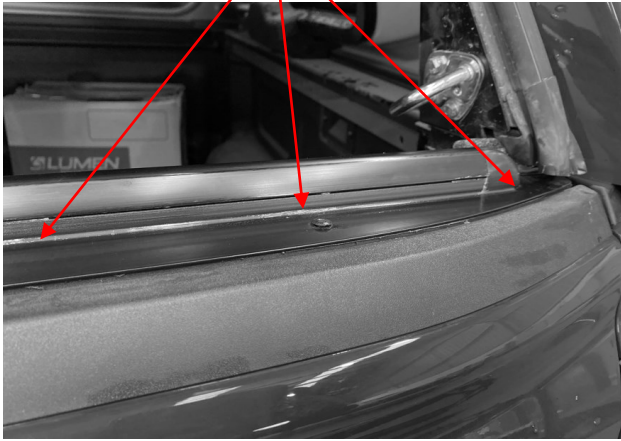

2.12) Run bead of silicon between vertical and horizontal intersecting faces of the ledge of the canopy door tailgate tub stop assembly along entire length as shown (A) between the powder coated bracket and the upright aluminium extrusion assembly with rubber seal, wipe off any excess.

2.13) Check all bolts are tight and check the vehicle's tailgate operation by opening and closing ensuring the tailgate functions and the seals makes contact to the tailgate.